



*SERVING THE FOOD INDUSTRY SINCE 1951*

## TRASH RECEPTACLE FOR 36-GALLON BIN

Item: 46584

**Omcan's trash bin receptacle** with swing door provides the excellent compact solution for waste management. It is the perfect companion for restaurants, healthcare facilities, schools, offices, and hotels. Features an engraved message to reiterate the gratitude towards your customers as well as a recessed top for discarded food trays.



Assembly required. Please inquire regarding our assembly service



Authorized Dealer

## FEATURES:

- Fits Standard 36 gallon / 136 litre bin
- Laminated melamine
- Hinged opening with engraved “thank you” message
- Food tray holder on top area
- Swing door for ease of cleaning

## TECHNICAL SPECIFICATION

ITEM NUMBER	46584
MATERIAL	Plywood / Melamine
COLOR	Black
NET WEIGHT	94.80 LBS / 43KGS
GROSS WEIGHT	99.20 LBS/ 45KGS
DIMENSIONS (DWH)	22" x 22" x 47" / 558.80 x 558.80 x 1193.80 mm
PACKAGING DIMENSIONS	48" x 22.5" x 4.75" / 1219 x 571.5 x 120.7 mm

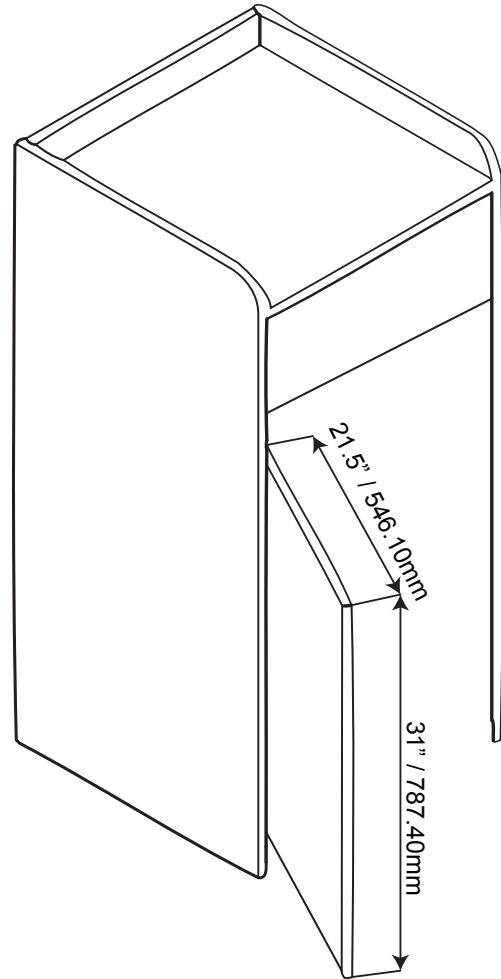
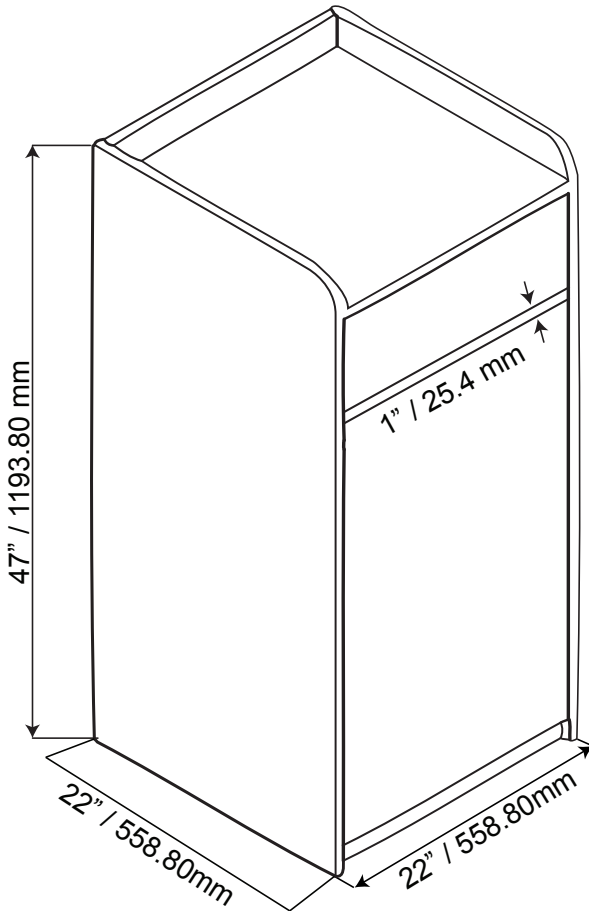

## OMCAN INC.

Telephone: 1-800-465-0234  
 Fax: (905) 607-0234  
 Email: sales@omcan.com  
 Website: www.omcan.com



Follow us to keep up to date with the latest news and offers

